

Design and Development of Solar Assisted Bicycle

M. Reddi Sankar^{#1}, T. Pushpaveni^{#2}, V. Bhanu Prakash Reddy^{#3}

Dept. Of EConE, Sree Vidyanikethan Engineering College
Tirupathi

¹reddisankarsana@gmail.com

²pushpat44@gmail.com

³bhanu0822@gmail.com

Abstract — As we all know the fuel prices especially the petrol is rising steadily day by day. Again the pollution due to vehicles in metro cities & urban areas is increasing continuously. To overcome these problems, an effort is being made to search some other alternative sources of energy for the vehicles. Again, it is also not affordable to purchase vehicles (mopeds, scooters or motorcycles) for all the class of society. Keeping this in mind, a search for some way to cater these economically poor people as well as to provide a solution for the environmental pollution was in progress. The solar assisted bicycle developed is driven by DC motor fitted in front or rear axle housing & operated by solar energy. The solar panels mounted on the carriage will charge the battery & which in turn drive the hub motor. When the bicycle is idle, the solar panel will charge the battery. This arrangement will replace the petrol engine, the gear box & the fuel tank in case of a two wheeler or a chain sprocket, chain & gear shifting arrangement of a conventional bicycle being used by most common man. [9] As a part of dissertation work, the solar assisted bicycle is fitted with a dc hub motor on front axle of a bicycle with power rating of 250W and with a travelling speed of around 25-30 kmph. It is provided with a pair of lead acid batteries of 35 Ah each, a photovoltaic solar panel with capacity of 20 watt, a voltage regulator of 24v 10 Amp, accelerator and motor controller of 24v 25Amp. There is also a provision for charging of the battery with 220-240V, AC wall outlet supply, in case of poor solar supply due to cloudy weather. [4]

inside. The stator (Fig.3) is mounted and fixed onto the axle and the hub will be made to rotate by alternating currents supplied through batteries. Hub motor generates high torque at low speed, which is highly efficient and which doesn't need sprockets, brackets and drive chains. This means they are very reliable and have a long life. The main characteristic of Brushless DC Machines is that they may be controlled to give wide constant power speed ranges.^{[10][11][12]}



Fig 2: Hub Motor Rotor



Fig 3: Hub Motor stator

Index Terms - Solar Assisted Bicycle (SAB), Hub Motor, SolarPanel, Motor Controller, Voltage Regulator.

I. METHODOLOGY

The solar assisted bicycle consist of following components (fig.1) – hub motor, solar panel, voltage regulator, lead acid battery, motor controller, accelerator, bicycle^[9].

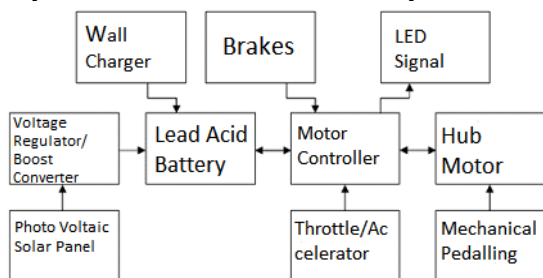

Fig 1-Block diagram of solar assisted bicycle

A. Hub Motor

The hub motor is a conventional Dc motor. The rotor (Fig.2) is outside the stator with the permanent magnets mounted on

Table 1: Specifications of Hub Motor

Type of Motor	Hub motor
Design of Motor	BLDC (Brushless DC)
Power Rating	250W
Torque	12 N-m
Speed (rpm)	300
Rated Voltage (V)	24
Efficiency (%)	≥80
Noise(dB)	<65
Weight(kg)	4

B. Solar cells/Panels

As the title suggests the bicycle is operated by solar energy. The lead acid battery is charged with solar energy with the help of a solar cell. Solar cells convert the energy of sunlight directly into electricity through

the use of the photovoltaic effect. The photovoltaic effect involves the creation of a voltage into an electromagnetic radiation.

The photoelectric and photovoltaic effects are related to sunlight, but are different in that electrons are ejected from a material's surface upon exposure to radiation of sufficient energy in photoelectric, and generated electrons are transferred to different bands of valence to conduction within the material, resulting in the build-up of voltage between two electrodes in photovoltaic.

Solar cells are electrically connected and fabricated as a module with a sheet of glass on top to allow light to pass and protect the semiconductor from the weather. To obtain a desired peak DC voltage we will add solar cells in series, and to obtain a desired peak current, the solar cells are put in parallel position (Fig.4).



Fig 4: Solar panel

Table 2: Specifications of solar cell

Maximum Power (Watt)	20
Charging Current (Amp)	2
Open Circuit Voltage (V)	21.6
Max Power Voltage (V)	17
Short Circuit Current	1.316
Power Measured at Standard Test Condition	1000W per m2 at 25°C
Lifespan	25 years
Size	500mm × 338mm. × 35mm

C. Voltage Regulator

It is essential to regulate the voltage output from the solar panel before it is supplied to the battery. A voltage regulator is a power converter with an output DC voltage greater than the input DC voltage. This is used to regulate an input voltage to a higher regulated voltage.

The output of the solar panel is not always be stable due to fluctuations in intensity of sunlight, angular changes with respect to the direction of sunlight, as well as other environmental factors. This is the voltage regulator/Boost Converter comes into SAB. The output of the solar panel is the input of the boost converter, which then outputs into the battery for charging. Because the output of the solar panel will be varying constantly, we need a voltage regulator/boost converter that will take an input from a wide range of voltages and output a specific, constant voltage value.

A voltage regulator/boost converter is a power converter that will take in a DC voltage and output a higher value DC

voltage. Our voltage regulator/boost converter requires output of the solar panel, which can range from 0V to 27.2V, and output for charging of the battery.

We were initially attracted to the SPV Instruments (Fig.5, Fig.6) Module because it has the characteristics of taking in an input range of 9.6V to 13.2V and outputting 24V at a maximum of 2-3 amps .This SPV has an area of 2.5 square inches so it is also small in size, which makes it very feasible to be placed anywhere on the bicycle. We go thought the battery voltage & we need to supply 24V in order to charge it. [6]

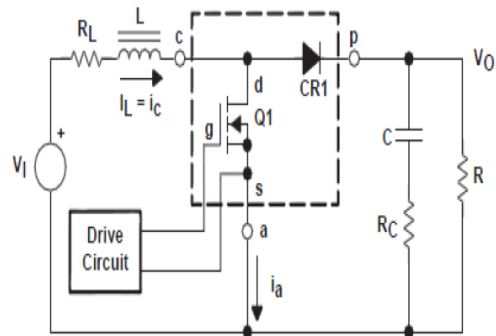

Fig 5: Circuit Diagram Of Voltage Regulator



Fig 6: Voltage regulator/Boost converter

Output Voltage	24 V
Open Circuit Voltage	26.8 V
Amp- Hour Rating	10 A

Table 3: Specification Of Solar Charger

D. Lead Acid Battery

Lead acid batteries (Fig.7) are one of the most popular types of battery in electronics. Although slightly lower in energy density than lithium metal, lead acid is safe, provided certain precautions are met when charging and discharging. This have a many advantages over other conventional types of batteries, the lead acid battery is the optimum choice for a solar assisted bicycle.

Current supplied from battery indicates the flow of energy from the battery and is measured in amperes (or Amps) (Fig.10). The higher the current flow faster the battery will discharge. A battery is rated in ampere-hours (abbreviated Ah) and this is called the battery capacity. (Fig.9)

This project revolves around supplying and utilizing energy within a high voltage battery (Fig.8). It demands for a battery with longer running hours, lighter

weight with respect to its high output voltage and higher energy density. Among all the existing rechargeable battery systems, the lead acid cell technology is the most efficient and practical choice for the desired application. The battery chosen for this project was a high capacity lead acid battery pack designed specifically for vehicles. Plastic casing is provided to house the internal components of the battery. [1]
[3]

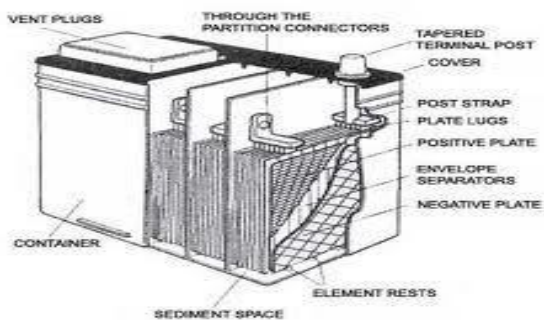

Fig 7: Parts of Lead Acid Battery Cell



Fig 8: Lead Acid Battery

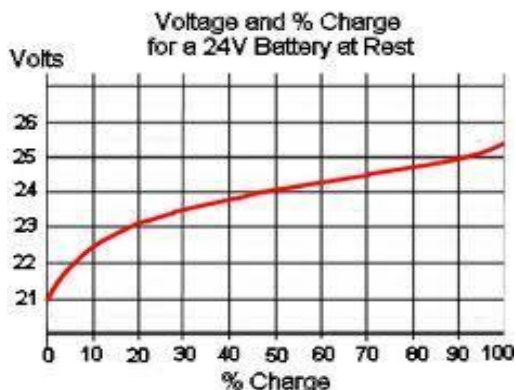

Fig 9: Voltage and % of Charge of Lead acid battery

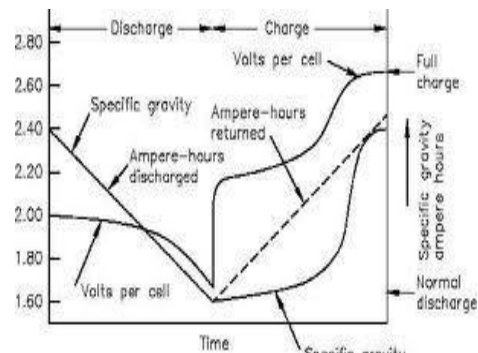

Fig 10: Charge per cell of Lead acid battery

Table 4: Specifications of Lead Acid Battery

Type of Battery	Sealed Lead Acid
Size (l x w x h)	210x140x356 mm.
Number of Batteries	Two Batteries connected in series
Voltage	12 V
Amp-Hour Rating	35 Ah
Charge Termination	When battery charge reaches 25.8 V
Standby Battery Voltage	25.4 V
Open Circuit Voltage (Volts)	2.87 V
Charging Time	8-9 hours
Weight	8 Kg
Safety	Good
Cycle Life (n0. Of cycles)	400
Operating Temperature °C	-10 to 60

E. Motor Controller

The motor controller (Fig.12) is an important component of the system. It is essential to control the amount of power supplied and to drive the BLDC hub motor. The controller converts the DC voltage from battery to an alternating voltage with variable amplitude and frequency that drive the hub motor at different speeds(Fig.11). It basically consists of MOSFET transistors and small microprocessor that vary from detecting any malfunctions with the motor hall sensors, the throttle, to protect functions against excessive current and under-voltage, which are ideal for protecting the system. [5]

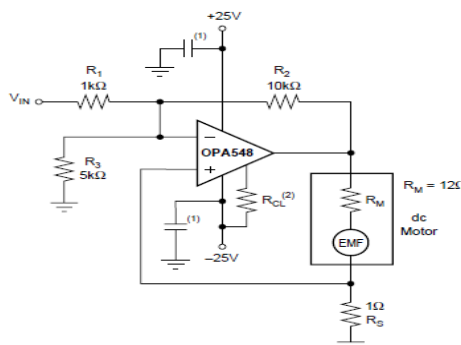

Fig 11: Circuit Diagram of Motor Controller



Fig 12: Hub Motor Controller

Table 5: Specifications of Motor Controller

System Voltage (V)	24
Max. Load Output Current	25
End Of Charge Voltage (V)	27.4
Boost Charge Voltage(V)	28.8
Ambient Temperature (°C)	0-50
Weight(gm.)	180
Dimensions(1×w×h)(mm)	130×88×39

F. Accelerator/Throttle

The maximum speed of a bicycle is 30 kmph. It is required to vary the speed depending upon the road conditions & traffic. Therefore an accelerator or a throttle (Fig.13) is necessary.

Throttle allows us to drive the motor from zero speed to full speed. The throttle is fitted on right side of the handle bar and is connected to controller. The throttle converts DC voltage from battery to an alternating voltage with variable amplitude and frequency that drives the hub motor at different speeds. It consists of MOSFET transistors and a small microprocessor.

This throttle is technically referred to as a Hall Effect type. The throttle has three wires contains a black, red, and green. The supply voltage is via red and black wires and is usually around 4 volts. Green wire voltage increases as the throttle is turned.



Fig 13: Throttle/Accelerator

Table 6: Specifications of Accelerator/Throttle

Supply Voltage (V)	24
Return Voltage (V)	4
Max. load output current (A)	25
Handle Bar Diameter(mm)	22
Three wires red, green, black	May differ from works. Fits for 24v supply

G. Solar Bicycle

” The solar assisted bicycle (Fig.14) is driven by DC motor fitted in front axle housing & operated by solar energy. The solar panel mounted on the carriage is charge the battery & which in turn drive the hub motor. When the bicycle is idle during the day, the solar panel will charge the battery. The system will make bicycle operate more efficiently

The basic configuration of an solar bicycle drive consists of a controller that controls the power flow from the battery to the electric motor. This power flow acts in parallel with the power delivered by the rider via the pedal of the bike. The rider of an solar bicycle can choose to rely on the motor completely, pedal and use the motor at the same time or pedal only (use as a conventional bicycle).

This arrangement replaces the petrol engines, the gear box and the fuel tankin case of a two wheeler or chain sprockets, chains & gear shifting arrangement of a conventional bicycle being used by most common man.^[9]

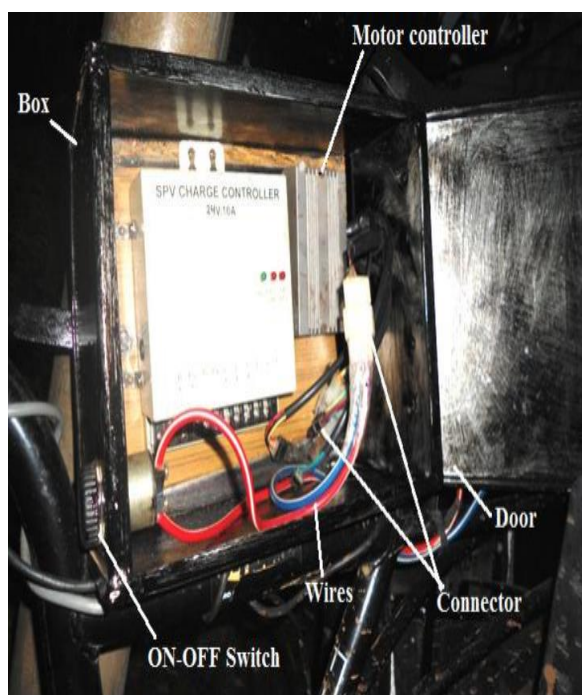

Fig 14: Solar Bicycle

Table 7: Specifications of a bicycle

Drive	Dual Powered (motor and pedal driven)
Weight	40 Kg
Riders Weight	80 kg
Load capacity	120 kg
Size	1410×540×1040 mm

II. RESULTS AND DISCUSSION:

Parameter	Solar Assisted Bicycle	Moped	Ordinary Bicycle
Max. Speed Limit (km/h)	25-30	45-50	10 to 15
Drivers pedalling requirement	No	No	Yes
Initial unit cost	16470	35000	3000
Operating cost for 40 km traveling in Rs.	Nil	45	Nil
Weight	40 kg	80 kg	15 kg
Max. Traveling distance at a stretch in km	35-40	150	15-20
fuel used per 100 km	Nil	2 L	Nil
Charging (oil- filling) time	6-7 hr. For 74W, 15A solar panels. & 16-18 hr. For 20W, 02A Solar panels.	Not applicable	Not applicable
Type of energy used	Solar	Petrol	Muscle power
Driving noise (dB)	noiseless	65- 70	noiseless
Driver's license required	No	Yes	No
Helmet Required	No	Yes	No
Age Limit	No	Yes, over 18	No
Engine size	Not applicable	100-125 cc	Not applicable

III. CONCLUSION

Solar assisted bicycle is modification of existing bicycle and driven by solar energy. It is suitable for both city and country roads, that are made of cement, asphalt, or mud. This bicycle is cheaper, simpler in construction & can be widely used for short distance travelling especially by school children, college students, office goers, villagers, postmen etc. It is very much suitable for young, aged, handicap people and caters the need of economically poor class of society. It can be operated throughout the year free of cost. The most important feature of this bicycle is that it does not consume valuable fossil fuels thereby saving crores of foreign currencies. It is ecofriendly & pollution free, as it does not have any emissions. Moreover it is noiseless and can be recharged with the AC adapter in case of emergency and cloudy weather. The operating cost per kilometer is minimal, around Rs.0.70/km. It can be driven by manual pedalling in case of any problem with the solar system. It has fewer components, can be easily mounted or dismantled, thus needs less maintenance.^[7]



REFERENCES

- [1] The Pandit G. Patil, Energy Systems Division, Argonne National Laboratory "Advanced Battery Technology for Electric Two-Wheelers" Journal of Energy Systems Division, Argonne National Laboratory June 2009.
- [2] Jean-Marc Timmermans¹, Julien Matheys, Philippe Lataire, Joeri Van Mierlo, Jan Cappelle² "A Comparative Study of 12 Electrically Assisted Bicycles" World Electric Vehicle Journal Vol. 3 - ISSN 2032-6653 - © 2009 AVERE.
- [3] Ahmad A. Pesaran and Tony Markel, Harshad S. Tataria, David Howell "Battery Requirements for Plug-In Hybrid Electric Vehicles – Analysis and Rationale" Conference Paper of National Renewable Energy Laboratory, USA NREL/CP-540-42240 July 2009.
- [4] Tony Markel, Michael Kuss, and Paul Denholm "Communication and Control of Electric Drive Vehicles Supporting Renewables" Conference Paper of Center for Transportation Technologies and Systems National Renewable Energy Laboratory, NREL/CP-540-46224 August 2009.
- [5] T. Markel, K. Bennion and W. Kramer, National Renewable Energy Laboratory & J. Bryan and J. Giedd Xcel Energy "Field Testing Plug-in Hybrid Electric Vehicles with Charge Control Technology in the Xcel Energy Territory." Technical Report of National Renewable Energy Laboratory, NREL/TP-550-46345, August 2009.
- [6] T. Markel, K. Bennion and W. Kramer, National Renewable Energy Laboratory & J. Bryan and J. Giedd Xcel Energy "Field Testing Plug-in Hybrid Electric Vehicles with Charge Control Technology in the Xcel Energy Territory" Journal of International Conference on Renewable Energies and Power Quality (ICREPQ'11) Las Palmas de Gran Canaria (Spain), 13th to 15th April, 2011.
- [7] C. E. (Sandy) Thomas "Fuel Cell and Battery Electric Vehicles Compared" Journal of H2Gen Innovations, Inc., Alexandria, Virginia, 22304, USA.
- [8] Todd Litman, "Efficient Vehicles Versus Efficient Transportation" "comparing transportation energy conservation strategies. Journal paper of Victoria Transport Policy Institute 26 August 2009.
- [9] An MIT Energy Initiative Symposium, "Electrification of the Transportation System". Journal paper of An MIT Energy Initiative Symposium April 8, 2010.
- [10] Chetan Kumar Maini, Deputy Chairman and Chief Technology officer, Reva Electric Car Company, India "Development of a next generation Electric Car for World Markets" Journal of EVS 24 Stavanger, Norway, May 13-16, 2009.
- [11] V.B. Bhandari, Design of machine elements, The McGraw. Hill Companies, Second Edition.
- [12] S.S. Ratan : Theory of Machine the McGraw, Hill Companies, Second Edition.